

7MBP200RA060

IGBT-IPM R series

600V / 200A 7 in one-package

Features

- Temperature protection provided by directly detecting the junction temperature of the IGBTs
- Low power loss and soft switching
- High performance and high reliability IGBT with overheating protection
- Higher reliability because of a big decrease in number of parts in built-in control circuit



Maximum ratings and characteristics

- Absolute maximum ratings(at $T_c=25^\circ\text{C}$ unless otherwise specified)

| Item | Symbol | Rating | | Unit | | |
|--|-----------------------------|----------------|----------|----------|------------------|---|
| | | Min. | Max. | | | |
| DC bus voltage | V_{DC} | 0 | 450 | V | | |
| DC bus voltage (surge) | $V_{DC(surge)}$ | 0 | 500 | V | | |
| DC bus voltage (short operating) | V_{SC} | 200 | 400 | V | | |
| Collector-Emitter voltage | V_{CES} | 0 | 600 | V | | |
| DB Reverse voltage | V_R | - | 600 | V | | |
| INV | Collector current | DC | I_C | - | 200 | A |
| | | 1ms | I_{CP} | - | 400 | A |
| | | Duty=57.8% | $-I_C$ | - | 200 | A |
| | Collector power dissipation | One transistor | P_C | - | 735 | W |
| DB | Collector current | DC | I_C | - | 75 | A |
| | | 1ms | I_{CP} | - | 150 | A |
| | Forward current of Diode | | I_F | - | 75 | A |
| | Collector power dissipation | One transistor | P_C | - | 320 | W |
| Junction temperature | | T_j | - | 150 | $^\circ\text{C}$ | |
| Input voltage of power supply for Pre-Driver | | V_{CC*1} | 0 | 20 | V | |
| Input signal voltage | | $V_{in} *2$ | 0 | V_Z | V | |
| Input signal current | | I_{in} | - | 1 | mA | |
| Alarm signal voltage | | V_{ALM*3} | 0 | V_{CC} | V | |
| Alarm signal current | | $I_{ALM} *4$ | - | 15 | mA | |
| Storage temperature | | T_{stg} | -40 | 125 | $^\circ\text{C}$ | |
| Operating case temperature | | T_{op} | -20 | 100 | $^\circ\text{C}$ | |
| Isolating voltage (Case-Terminal) | | $V_{iso} *5$ | - | AC2.5 | kV | |
| Screw torque | Mounting (M5) | - | 3.5 *6 | N·m | | |
| | Terminal (M5) | - | 3.5 *6 | N·m | | |

*1 Apply V_{CC} between terminal No. 3 and 1, 6 and 4, 9 and 7, 11 and 10.

*2 Apply V_{in} between terminal No. 2 and 1, 5 and 4, 8 and 7, 12,13,14,15 and 10.

*3 Apply V_{ALM} between terminal No. 16 and 10.

*4 Apply I_{ALM} to terminal No. 16.

*5 50Hz/60Hz sine wave 1 minute.

*6 Recommendable Value : 2.5 to 3.0 N·m

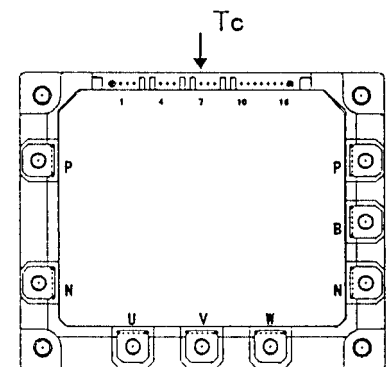

Fig.1 Measurement of case temperature

- Electrical characteristics of power circuit (at $T_c=T_j=25^\circ\text{C}$, $V_{CC}=15\text{V}$)

| Item | Symbol | Condition | Min. | Typ. | Max. | Unit | |
|------|---------------------------------------|---------------|--|------|------|------|----|
| INV | Collector current at off signal input | I_{CES} | $V_{CE}=600\text{V}$ input terminal open | - | - | 1.0 | mA |
| | Collector-Emitter saturation voltage | $V_{CE(sat)}$ | $I_C=200\text{A}$ | - | - | 2.8 | V |
| | Forward voltage of FWD | V_F | $-I_C=200\text{A}$ | - | - | 3.0 | V |
| DB | Collector current at off signal input | I_{CES} | $V_{CE}=600\text{V}$ input terminal open | - | - | 1.0 | mA |
| | Collector-Emitter saturation voltage | $V_{CE(sat)}$ | $I_C=75\text{A}$ | - | - | 2.8 | V |
| | Forward voltage of Diode | V_F | $-I_C=75\text{A}$ | - | - | 3.3 | V |

● Electrical characteristics of control circuit(at Tc=Tj=25°C, Vcc=15V)

| Item | Symbol | Condition | Min. | Typ. | Max. | Unit | |
|--|---------------------|---|---|------|------|------|---|
| Power supply current of P-line side Pre-driver(one unit) | I _{ccp} | fsw=0 to 15kHz Tc=-20 to 100°C *7 | 6 | - | 32 | mA | |
| Power supply current of N-line side three Pre-driver | I _{ccn} | fsw=0 to 15kHz Tc=-20 to 100°C *7 | 24 | - | 114 | mA | |
| Input signal threshold voltage (on/off) | V _{in(th)} | ON | 1.00 | 1.35 | 1.70 | V | |
| | | OFF | 1.70 | 2.05 | 2.40 | V | |
| Input zener voltage | V _z | R _{in} =20k ohm | - | 8.0 | - | V | |
| Over heating protection temperature level | T _{COH} | VDC=0V, I _c =0A, Case temperature, Fig.1 | 110 | - | 125 | °C | |
| Hysteresis | T _{CH} | | - | 20 | - | °C | |
| IGBT chips over heating protection temperature level | T _{JOH} | surface of IGBT chips | 150 | - | - | °C | |
| Hysteresis | T _{JH} | | - | 20 | - | °C | |
| Collector current protection level | INV | I _{oc} | T _j =125°C Collector current | 300 | - | - | A |
| | DB | I _{oc} | T _j =125°C Collector current | 113 | - | - | A |
| Over current protection delay time (Fig.2) | t _{DOC} | T _j =25°C Fig.2 | - | 10 | - | µs | |
| Under voltage protection level | V _{UV} | | 11.0 | - | 12.5 | V | |
| Hysteresis | V _H | | 0.2 | - | - | V | |
| Alarm signal hold time | t _{ALM} | | 1.5 | 2 | - | ms | |
| SC protection delay time | t _{SC} | T _j =25°C Fig.3 | - | - | 12 | µs | |
| Limiting resistor for alarm | R _{ALM} | | 1425 | 1500 | 1575 | ohm | |

*7 Switching frequency of IPM

● Dynamic characteristics(at Tc=Tj=125°C, Vcc=15V)

| Item | Symbol | Condition | Min. | Typ. | Max. | Unit |
|-----------------------|-----------------|--------------------------------|------|------|------|------|
| Switching time (IGBT) | ton | I _C =200A, VDC=300V | 0.3 | - | - | µs |
| | toff | | - | - | 3.6 | µs |
| Switching time (FWD) | t _{tr} | I _F =200A, VDC=300V | - | - | 0.4 | µs |

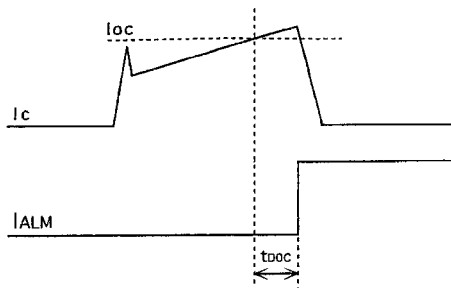

Fig.2 Definition of OC delay time

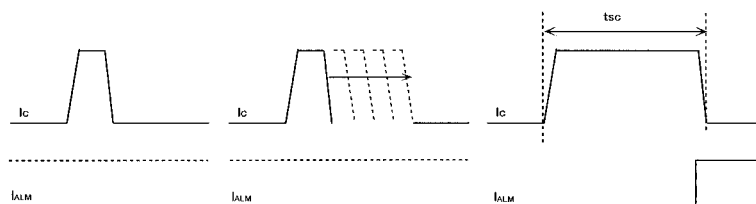

Fig.3 Definition of tsc

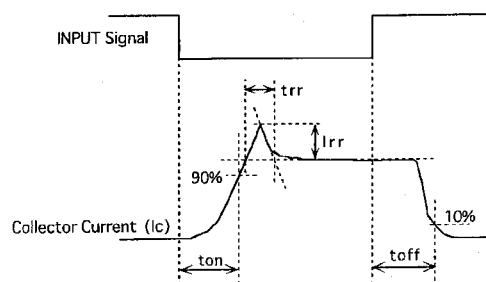

Fig.4 Definition of switching time

● Thermal characteristics(Tc=25°C)

| Item | Symbol | Typ. | Max. | Unit |
|--|----------------------|------|------|------|
| Junction to Case thermal resistance | INV | IGBT | 0.17 | °C/W |
| | | FWD | 0.36 | °C/W |
| | DB | IGBT | 0.39 | °C/W |
| Case to fin thermal resistance with compound | R _{th(c-f)} | 0.05 | - | °C/W |

● Recommendable value

| Item | Symbol | Min. | Typ. | Max. | Unit |
|--|-----------------|------|------|------|------|
| DC bus voltage | V _{DC} | 200 | - | 400 | V |
| Operating power supply voltage range of Pre-driver | V _{CC} | 13.5 | 15 | 16.5 | V |
| Switching frequency of IPM | fsw | 1 | - | 20 | kHz |
| Screw torque | Mounting (M5) | 2.5 | - | 3.0 | N·m |
| | Terminal (M5) | 2.5 | - | 3.0 | N·m |

Block diagram

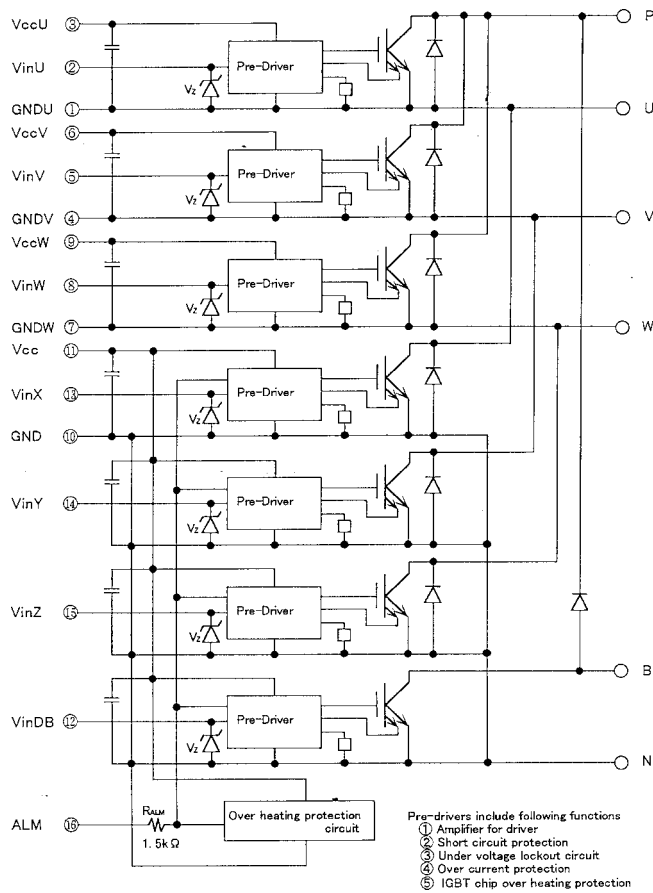

Pre-drivers include following functions

- a) Amplifier for driver
- b) Short circuit protection
- c) Undervoltage lockout circuit
- d) Over current protection
- e) IGBT chip over heating protection

Outline drawings, mm

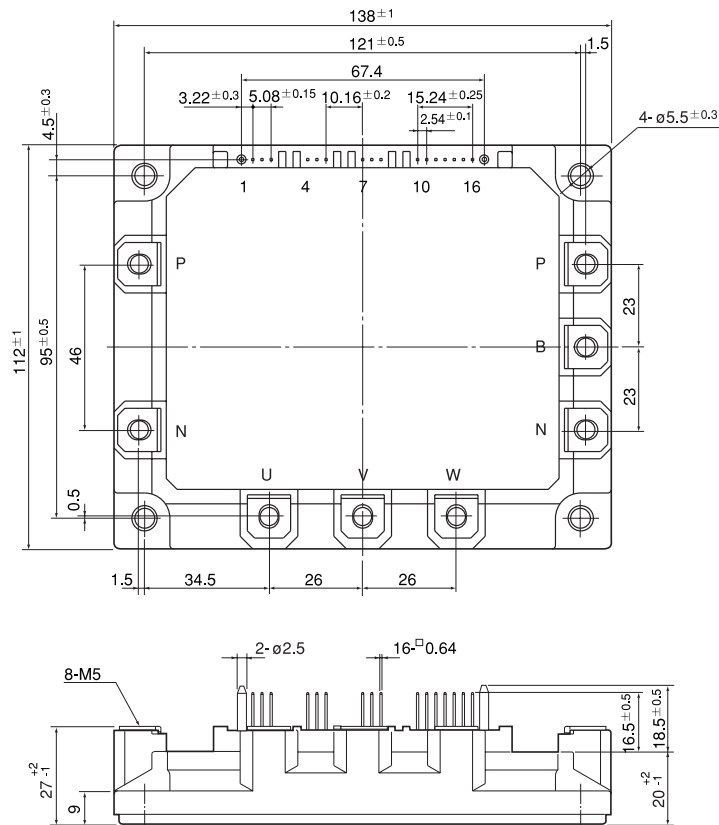

Mass : 920g

Characteristics (Representative)

Control circuit

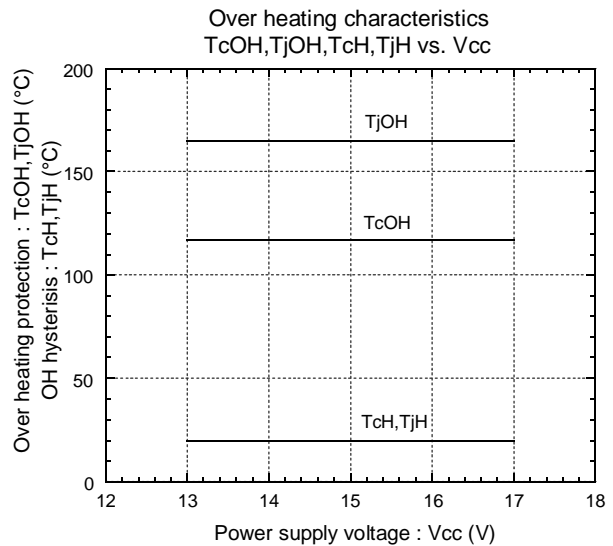
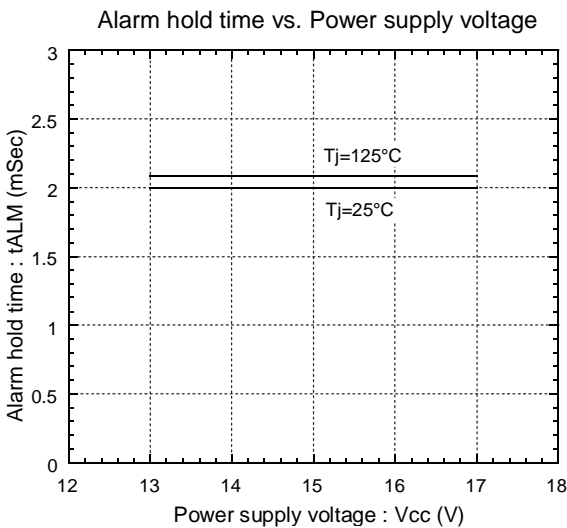
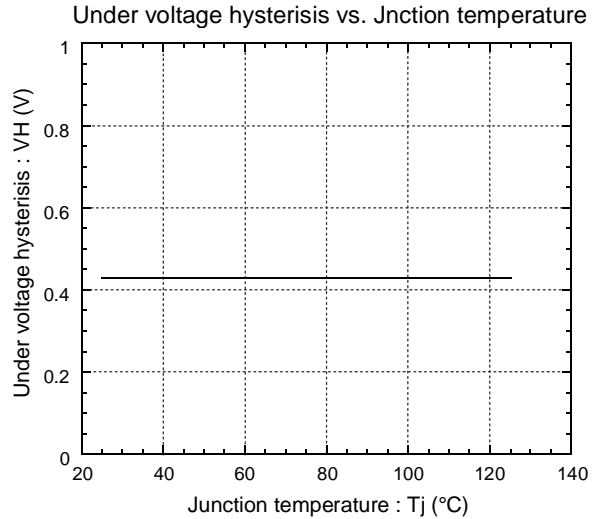
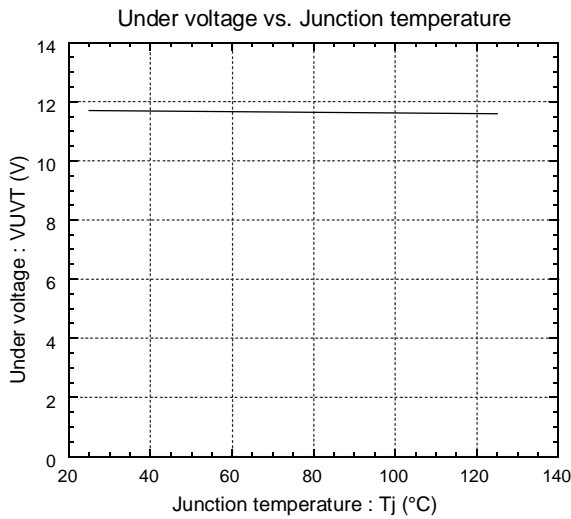
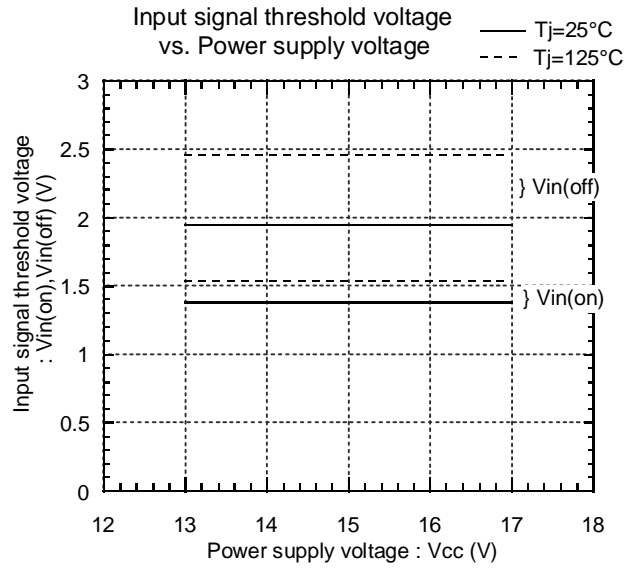
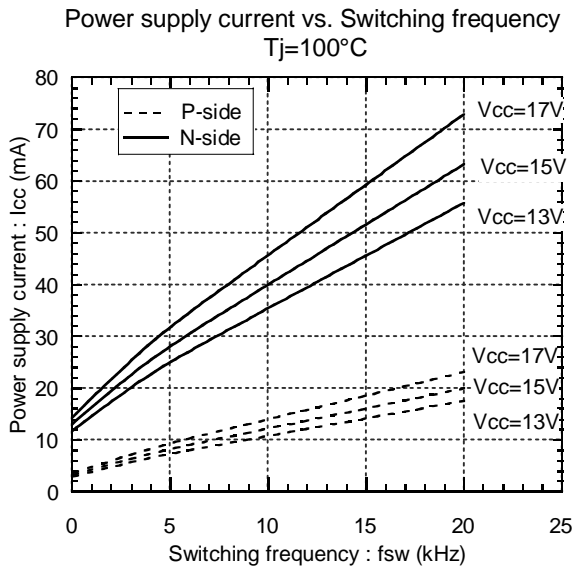

● Inverter

Collector current vs. Collector-Emittter voltage
T_j=25°C

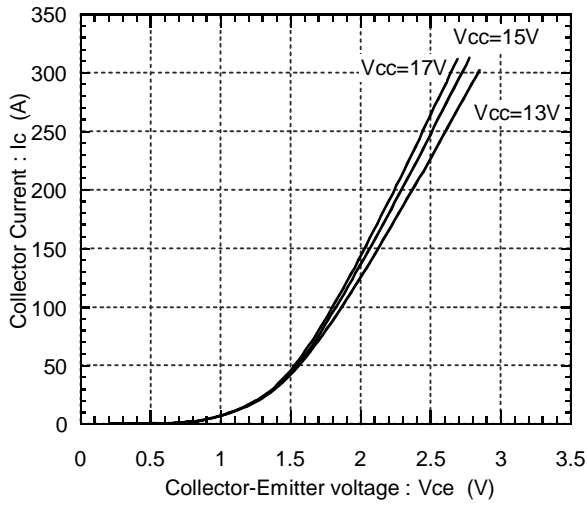

Collector current vs. Collector-Emittter voltage
T_j=125°C

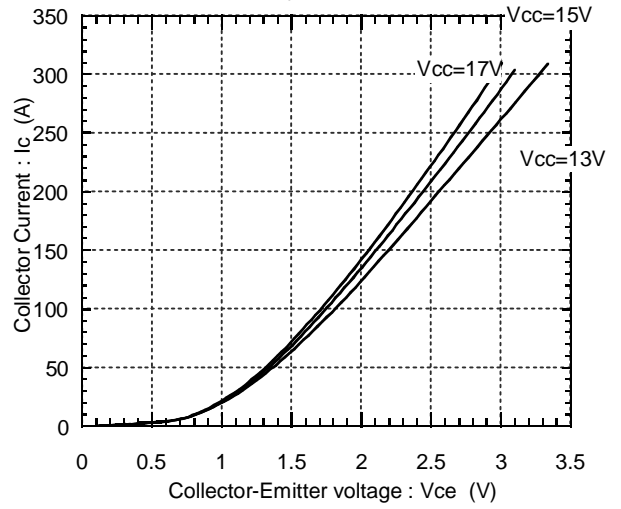

Switching time vs. Collector current
E_{dc}=300V, V_{cc}=15V, T_j=25°C

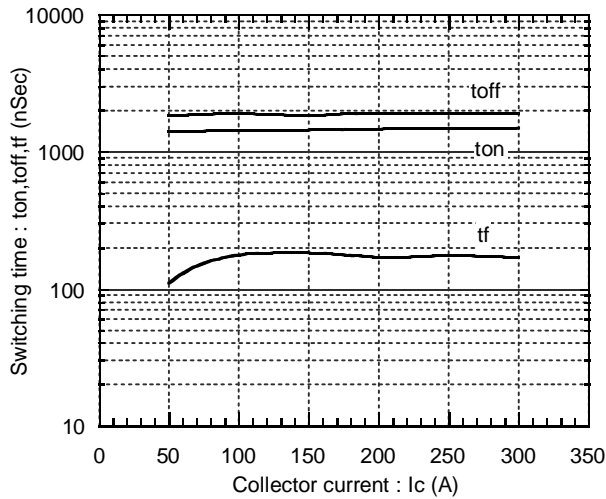

Switching time vs. Collector current
E_{dc}=300V, V_{cc}=15V, T_j=125°C

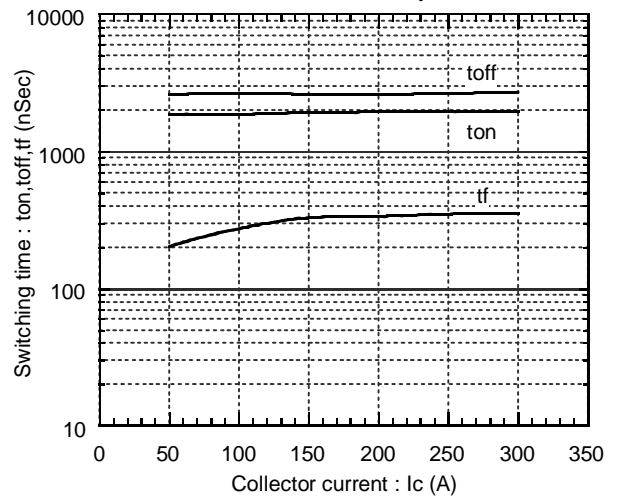

Forward current vs. Forward voltage

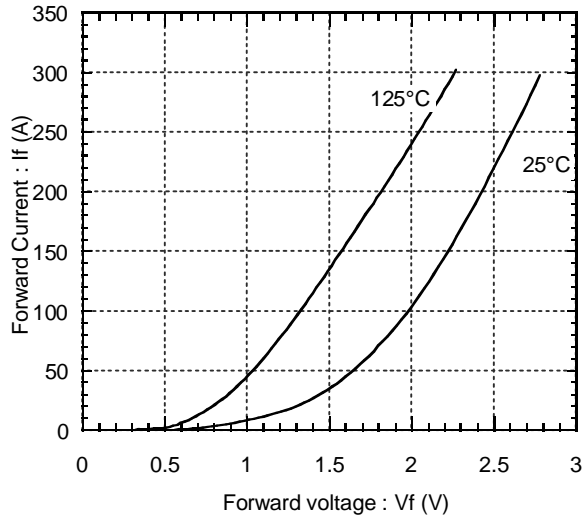

Reverse recovery characteristics
trr, Irr vs. IF

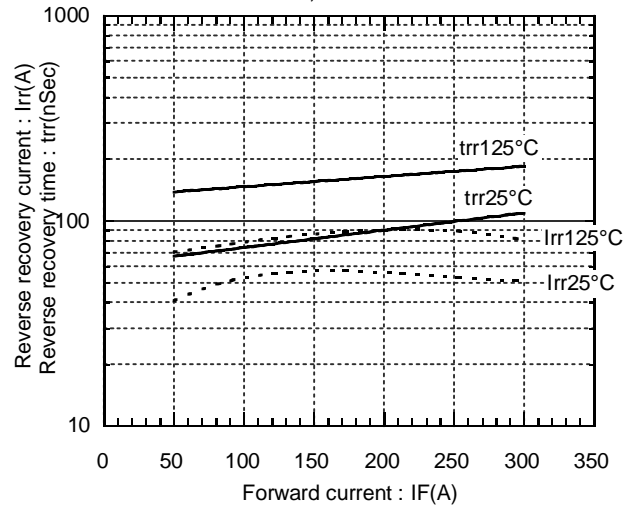

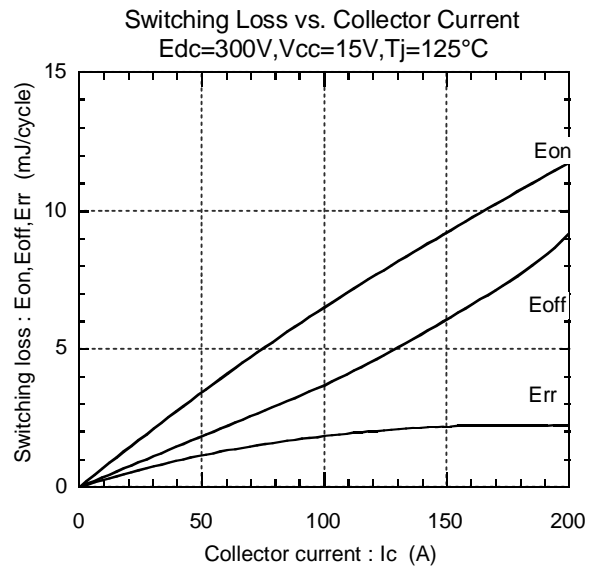
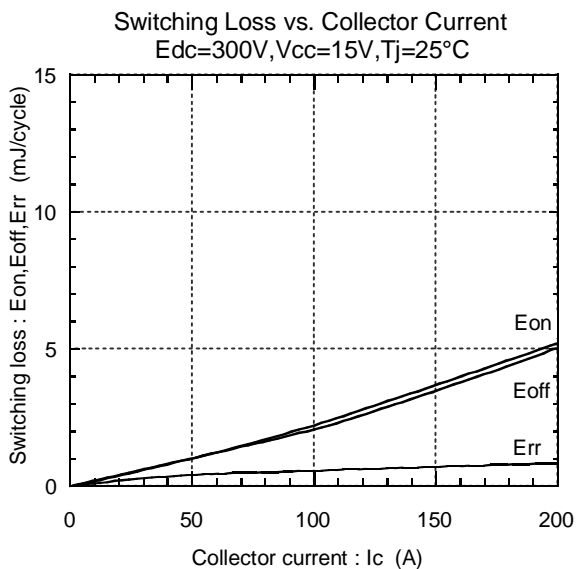
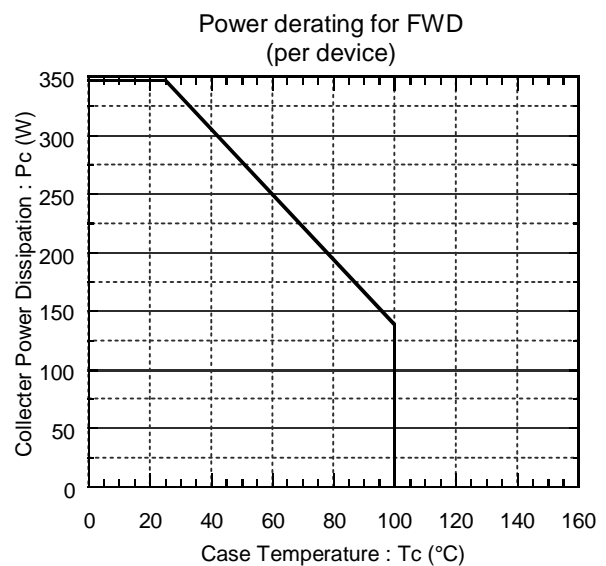
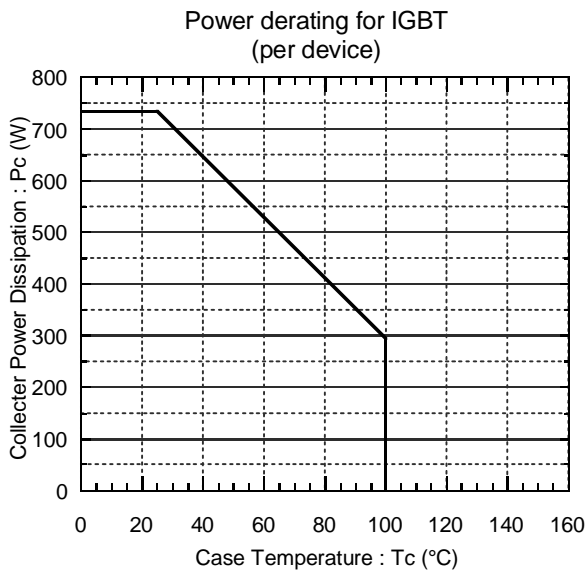
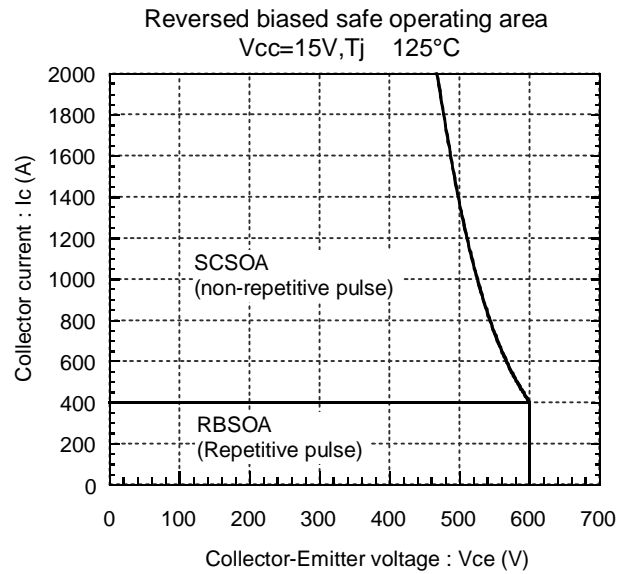
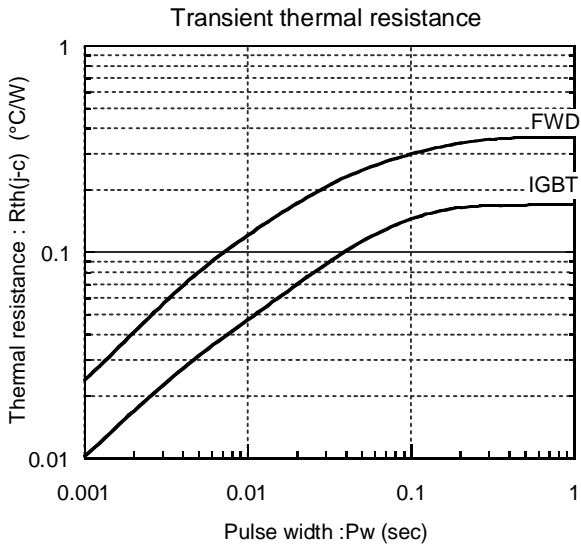

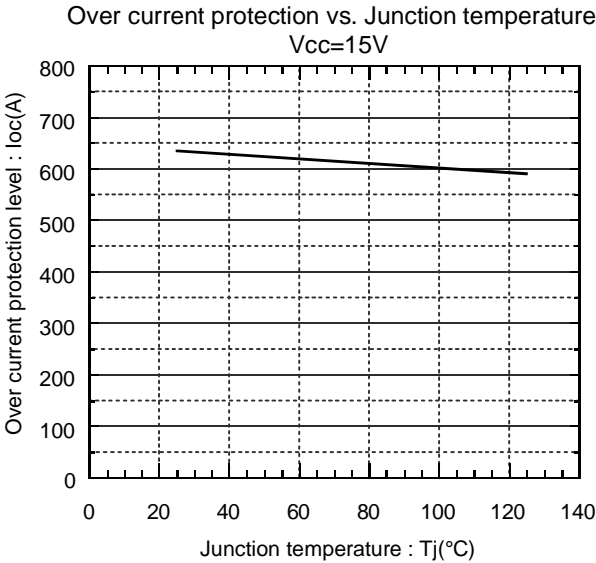

● Brake

Collector current vs. Collector-Emitter voltage
Tj=25°C

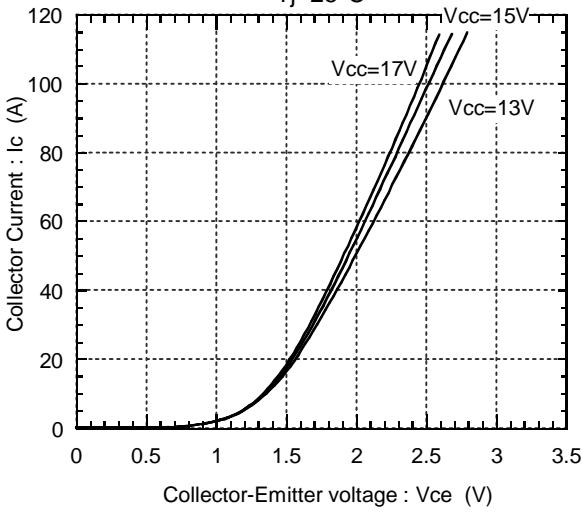

Collector current vs. Collector-Emitter voltage
Tj=125°C

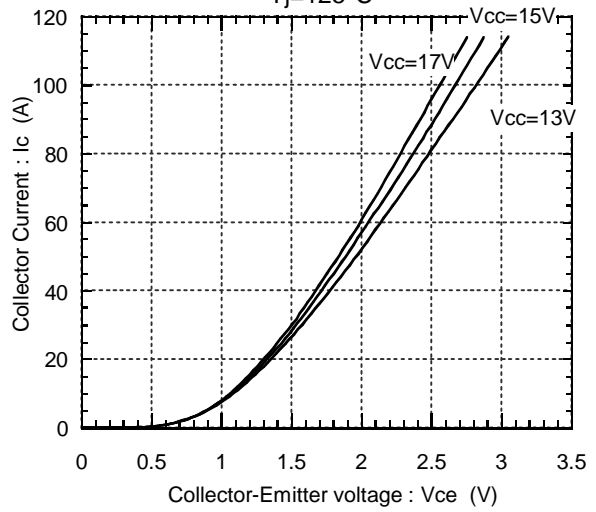

Transient thermal resistance

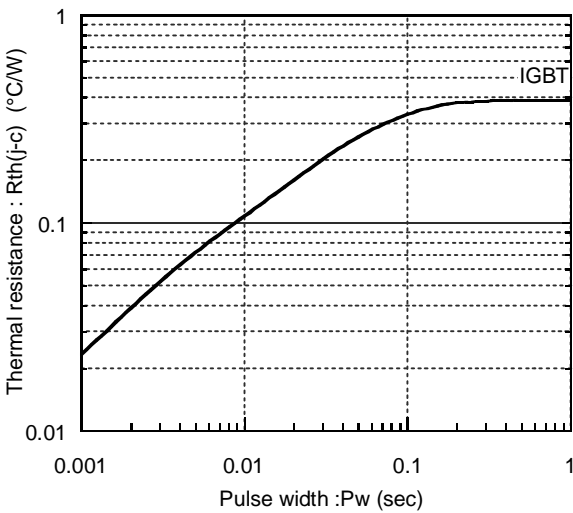

Reversed biased safe operating area
Vcc=15V, Tj 125°C

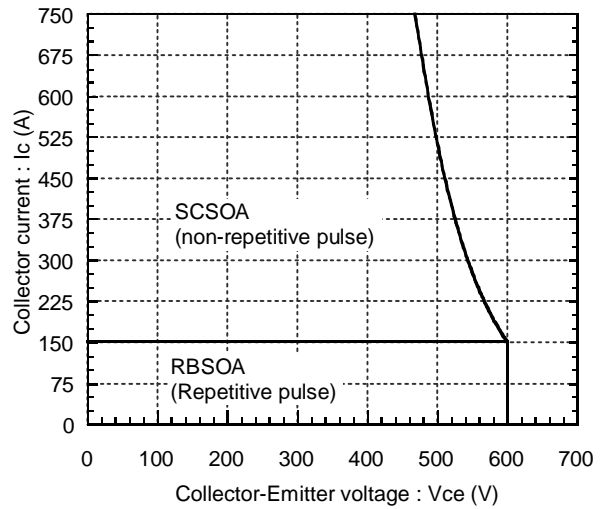

Power derating for IGBT
(per device)

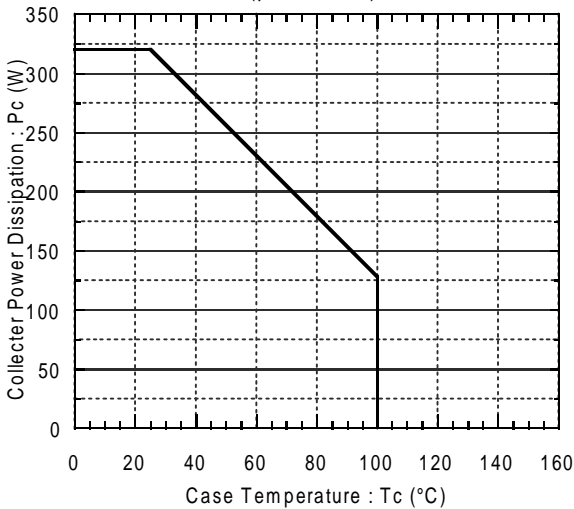

Over current protection vs. Junction temperature
Vcc=15V

