

PS21564

TRANSFER-MOLD TYPE
INSULATED TYPE

PS21564

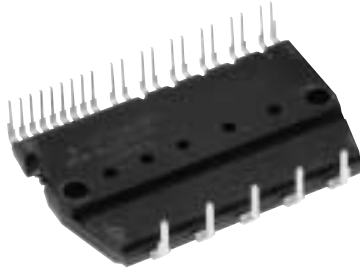

INTEGRATED POWER FUNCTIONS

600V/15A low-loss 5th generation IGBT inverter bridge for 3 phase DC-to-AC power conversion

INTEGRATED DRIVE, PROTECTION AND SYSTEM CONTROL FUNCTIONS

- For upper-leg IGBTs : Drive circuit, High voltage isolated high-speed level shifting, Control supply under-voltage (UV) protection.
- For lower-leg IGBTs : Drive circuit, Control supply under-voltage protection (UV), Short circuit protection (SC). (Fig.3)
- Fault signaling : Corresponding to an SC fault (Lower-side IGBT) or a UV fault (Lower-side supply).
- Input interface : 5V line CMOS/TTL compatible. (High Active)
- UL Approved : Yellow Card No. E80276

APPLICATION

AC100V~200V three-phase inverter drive for small power motor control.

Fig. 1 PACKAGE OUTLINES

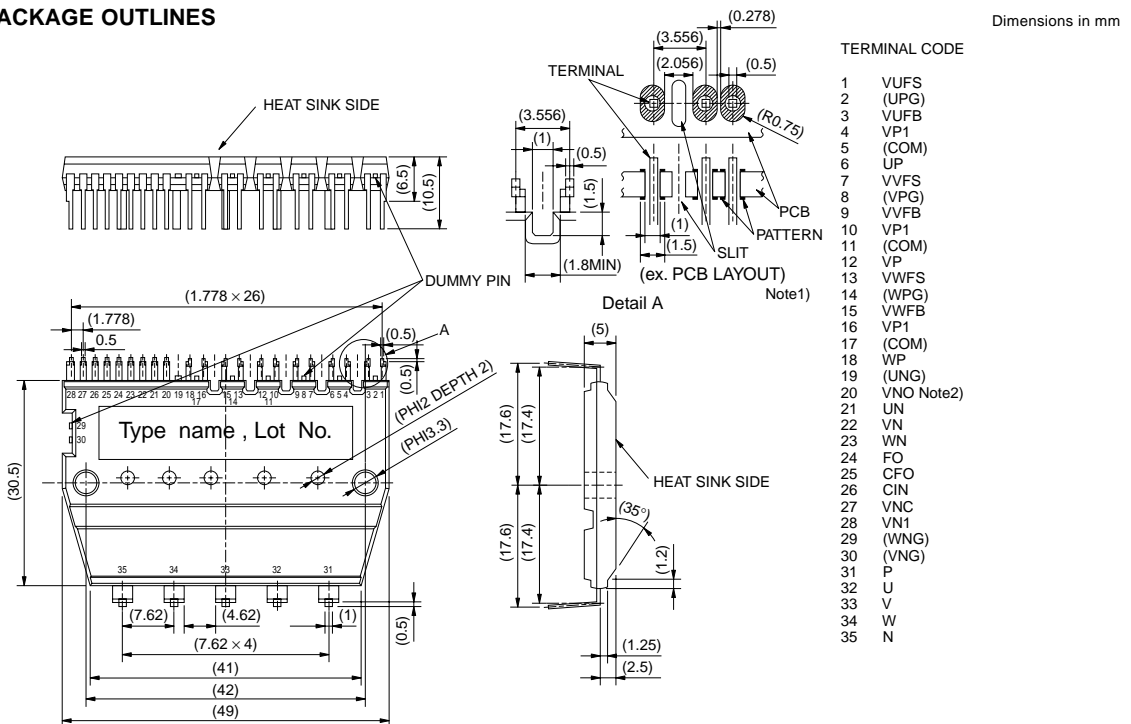

- Note 1 :** In order to get enough creepage distance between the terminals, please take some countermeasure such as a slit on PCB.
2 : Treat the terminal VNO of PS21564 as NC (just the same as DIP-IPM ver.2). However, external connection of VNO with N terminal is necessary for PS21562 or PS21563.

Fig. 2 INTERNAL FUNCTIONS BLOCK DIAGRAM (TYPICAL APPLICATION EXAMPLE)

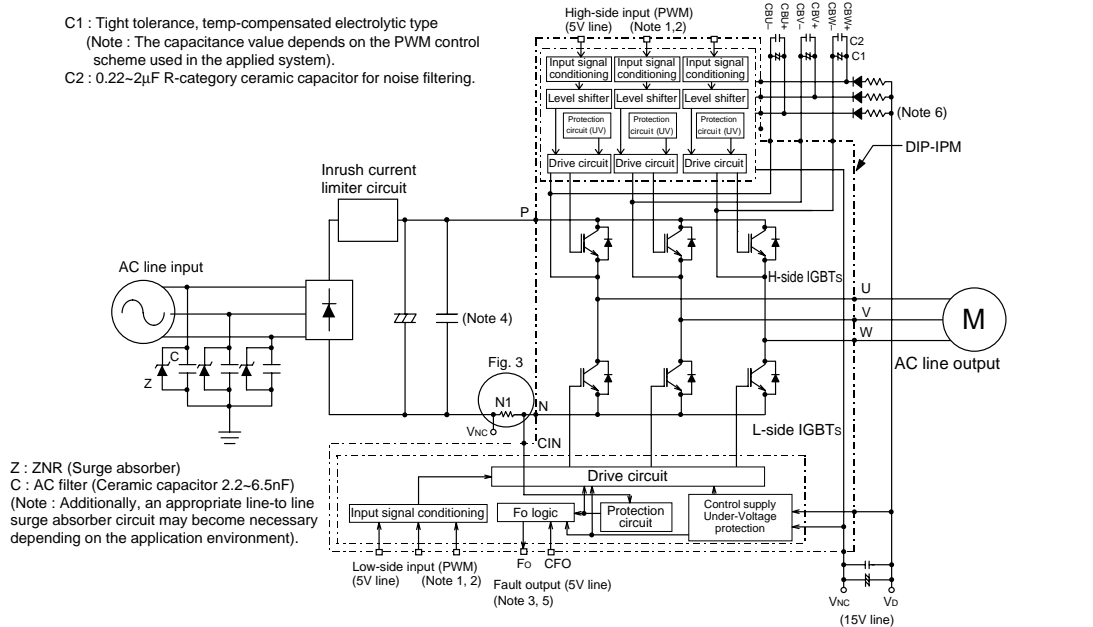
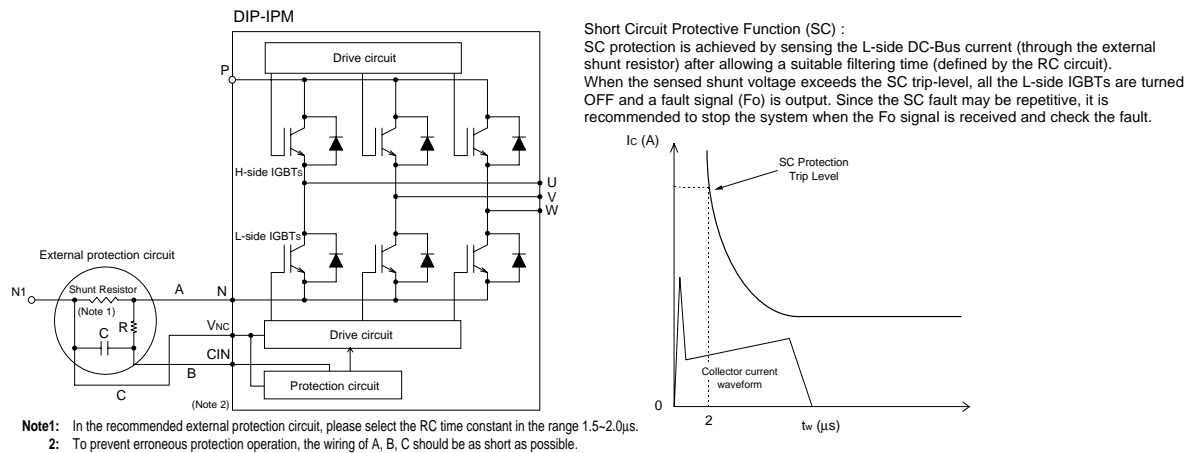

Fig. 3 EXTERNAL PART OF THE DIP-IPM PROTECTION CIRCUIT



MAXIMUM RATINGS ($T_j = 25^\circ\text{C}$, unless otherwise noted)

INVERTER PART

Symbol	Parameter	Condition	Ratings	Unit
V _{CC}	Supply voltage	Applied between P-N	450	V
V _{CC(surge)}	Supply voltage (surge)	Applied between P-N	500	V
V _{CES}	Collector-emitter voltage		600	V
±I _C	Each IGBT collector current	$T_f = 25^\circ\text{C}$	15	A
±I _{CP}	Each IGBT collector current (peak)	$T_f = 25^\circ\text{C}$, less than 1ms	30	A
P _C	Collector dissipation	$T_f = 25^\circ\text{C}$, per 1 chip	22.2	W
T _j	Junction temperature	(Note 1)	-20~+125	°C

Note 1 : The maximum junction temperature rating of the power chips integrated within the DIP-IPM is 150°C (@ $T_f \leq 100^\circ\text{C}$) however, to ensure safe operation of the DIP-IPM, the average junction temperature should be limited to $T_{j(ave)} \leq 125^\circ\text{C}$ (@ $T_f \leq 100^\circ\text{C}$).

CONTROL (PROTECTION) PART

Symbol	Parameter	Condition	Ratings	Unit
V _D	Control supply voltage	Applied between VP1-VNC, VN1-VNC	20	V
V _{DB}	Control supply voltage	Applied between VUFB-VUFS, VVFB-VVFS, VWFB-VWFS	20	V
V _{IN}	Input voltage	Applied between UP, VP, WP-VNC, UN, VN, WN-VNC	-0.5~V _D +0.5	V
V _{FO}	Fault output supply voltage	Applied between FO-VNC	-0.5~V _D +0.5	V
I _{FO}	Fault output current	Sink current at FO terminal	1	mA
V _{SC}	Current sensing input voltage	Applied between CIN-VNC	-0.5~V _D +0.5	V

TOTAL SYSTEM

Symbol	Parameter	Condition	Ratings	Unit
V _{CC(PROT)}	Self protection supply voltage limit (short circuit protection capability)	V _D = 13.5~16.5V, Inverter part $T_j = 125^\circ\text{C}$, non-repetitive, less than 2 μs	400	V
T _f	Module case operation temperature	(Note 2)	-20~+100	°C
T _{stg}	Storage temperature		-40~+125	°C
V _{iso}	Isolation voltage	60Hz, Sinusoidal, AC 1 minute, connection pins to heat-sink plate	2500	V _{rms}

Note 2 : T_f MEASUREMENT POINT

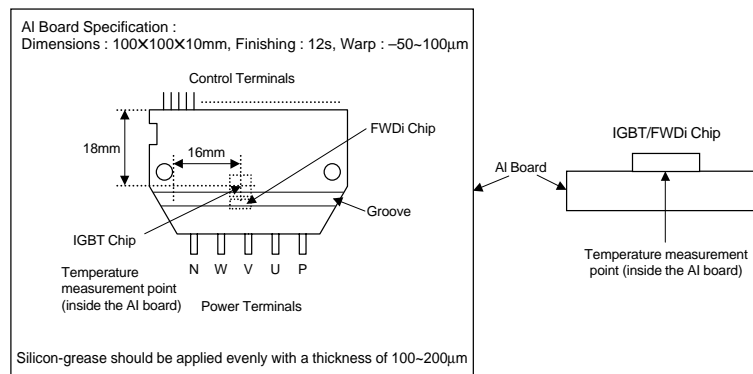

THERMAL RESISTANCE

Symbol	Parameter	Condition	Limits			Unit
			Min.	Typ.	Max.	
R _{th(j-f)Q}	Junction to case thermal resistance (Note 3)	Inverter IGBT part (per 1/6 module)	—	—	4.5	°C/W
R _{th(j-f)F}		Inverter FWDi part (per 1/6 module)	—	—	6.5	°C/W

Note 3: Grease with good thermal conductivity should be applied evenly with about +100μm~+200μm on the contacting surface of DIP-IPM and heat-sink.

ELECTRICAL CHARACTERISTICS (T_j = 25°C, unless otherwise noted)

INVERTER PART

Symbol	Parameter	Condition	Limits			Unit
			Min.	Typ.	Max.	
V _{CE(sat)}	Collector-emitter saturation voltage	V _D = V _{DB} = 15V I _C = 15A, T _j = 25°C V _{IN} = 5V I _C = 15A, T _j = 125°C	—	1.45	1.95	V
V _{EC}	FWDi forward voltage	T _j = 25°C, -I _C = 15A, V _{IN} = 0V	—	1.50	2.00	V
t _{on}	Switching times	V _{CC} = 300V, V _D = V _{DB} = 15V I _C = 15A, T _j = 125°C, V _{IN} = 0 ↔ 5V Inductive load (upper-lower arm)	0.60	1.20	1.80	μs
t _{tr}			—	0.30	—	μs
t _{c(on)}			—	0.40	0.60	μs
t _{off}			—	1.50	2.10	μs
t _{c(off)}			—	0.50	0.80	μs
I _{CEs}			Collector-emitter cut-off current	V _{CE} = V _{CEs} T _j = 25°C T _j = 125°C	—	—

CONTROL (PROTECTION) PART

Symbol	Parameter	Condition	Limits			Unit	
			Min.	Typ.	Max.		
I _D	Circuit current	V _D = V _{DB} = 15V V _{IN} = 5V	Total of V _{P1} -V _{NC} , V _{N1} -V _{NC}	—	—	5.00	mA
			V _{UFB} -V _{UFS} , V _{VFB} -V _{VFS} , V _{WFB} -V _{WFS}	—	—	0.40	mA
		V _D = V _{DB} = 15V V _{IN} = 0V	Total of V _{P1} -V _{NC} , V _{N1} -V _{NC}	—	—	7.00	mA
			V _{UFB} -V _{UFS} , V _{VFB} -V _{VFS} , V _{WFB} -V _{WFS}	—	—	0.55	mA
V _{FOH}	Fault output voltage	V _{SC} = 0V, F _O circuit pull-up to 5V with 10kΩ	4.9	—	—	V	
V _{FOL}		V _{SC} = 1V, I _{FO} = 1mA	—	—	0.95	V	
V _{SC(ref)}	Short circuit trip level	T _j = 25°C, V _D = 15V (Note 4)	0.43	0.48	0.53	V	
I _{IN}	Input current	V _{IN} = 5V	1.0	1.5	2.0	mA	
UV _{DBt}	Supply circuit under-voltage protection	T _j ≤ 125°C	Trip level	10.0	—	12.0	V
UV _{DBr}			Reset level	10.5	—	12.5	V
UV _{Dt}			Trip level	10.3	—	12.5	V
UV _{Dr}			Reset level	10.8	—	13.0	V
t _{FO}	Fault output pulse width	C _{FO} = 22nF (Note 5)	1.0	1.8	—	ms	
V _{th(on)}	ON threshold voltage	Applied between UP, VP, WP-V _{NC} , UN, VN, WN-V _{NC}	2.1	2.3	2.6	V	
V _{th(off)}	OFF threshold voltage		0.8	1.4	2.1	V	

Note 4: Short circuit protection is functioning only at the low-arms. Please select the value of the external shunt resistor such that the SC trip-level is less than 25.5 A.

5: Fault signal is output when the low-arms short circuit or control supply under-voltage protective functions operate. The fault output pulse-width t_{FO} depends on the capacitance value of C_{FO} according to the following approximate equation : C_{FO} = 12.2 × 10⁻⁶ × t_{FO} [F].

PS21564

TRANSFER-MOLD TYPE
INSULATED TYPE

MECHANICAL CHARACTERISTICS AND RATINGS

Parameter	Condition		Limits			Unit
			Min.	Typ.	Max.	
Mounting torque	Mounting screw : M3	Recommended 0.78 N-m	0.59	—	0.98	N-m
Weight			—	20	—	g
Heat-sink flatness	(Note 6)		-50	—	100	μm

Note 6: Measurement point of heat-sink flatness

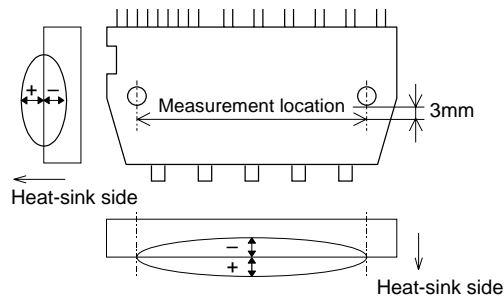

RECOMMENDED OPERATION CONDITIONS

Symbol	Parameter	Condition	Limits			Unit
			Min.	Typ.	Max.	
V _{CC}	Supply voltage	Applied between P-N	0	300	400	V
V _D	Control supply voltage	Applied between V _{P1} -V _{NC} , V _{N1} -V _{NC}	13.5	15.0	16.5	V
V _{DB}	Control supply voltage	Applied between V _{UFB} -V _{UFS} , V _{VFB} -V _{VFS} , V _{WFB} -V _{WFS}	13.0	15.0	18.5	V
ΔV _D , ΔV _{DB}	Control supply variation		-1	—	1	V/μs
t _{dead}	Arm shoot-through blocking time	For each input signal, T _f ≤ 100°C	2.0	—	—	μs
f _{PWM}	PWM input frequency	T _f ≤ 100°C, T _j ≤ 125°C	—	5	—	kHz
I _O	Allowable r.m.s. current	V _{CC} = 300V, V _D = 15V, f _c = 5kHz P.F = 0.8, sinusoidal T _j ≤ 125°C, T _f ≤ 100°C (Note 7)	—	—	7.5	Arms
P _{WIN}	Minimum input pulse width	ON (Note 8)	300	—	—	ns
V _{NC}	V _{NC} variation	between V _{NC} -N (including surge)	-5.0	—	5.0	V

Note 7 : The allowable r.m.s. current value depends on the actual application conditions.

8 : The input pulse width less than P_{WIN} might make no response.

Fig. 4 THE DIP-IPM INTERNAL CIRCUIT

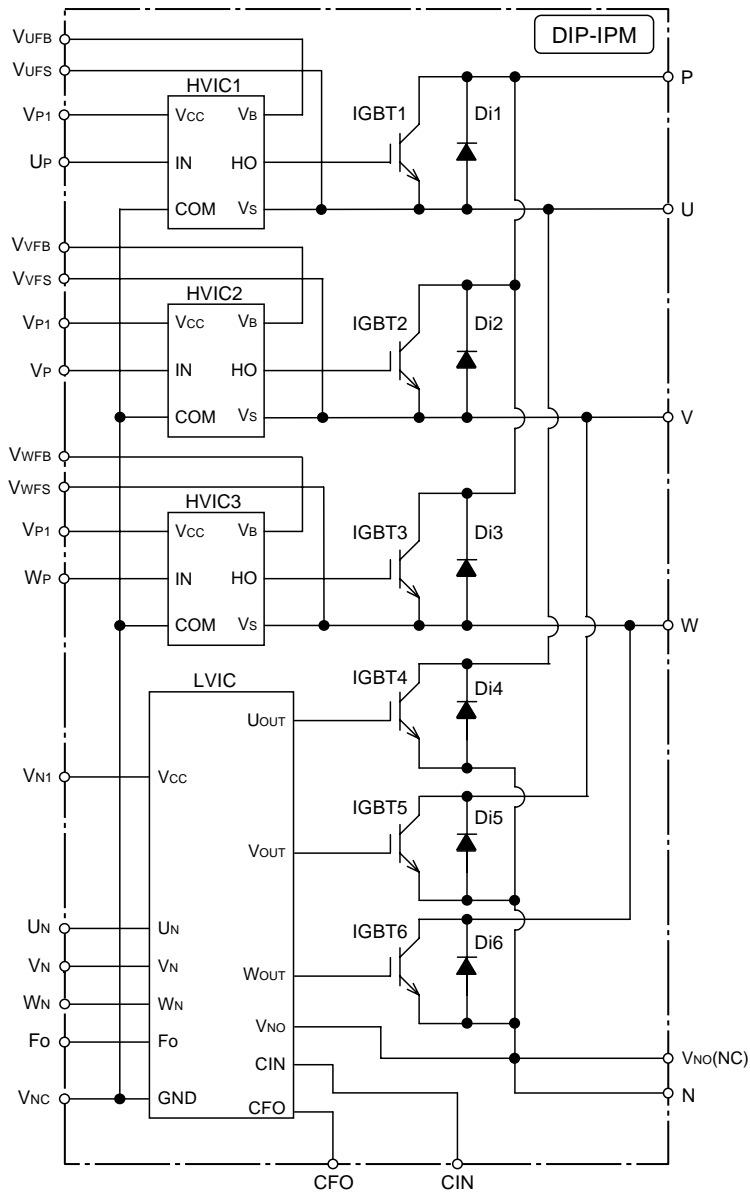
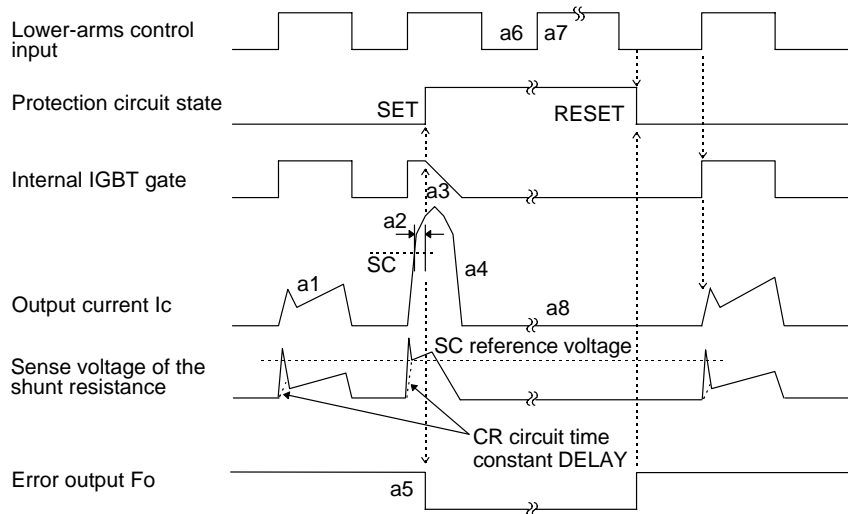

Fig. 5 TIMING CHARTS OF THE DIP-IPM PROTECTIVE FUNCTIONS

[A] Short-Circuit Protection (Lower-arms only)

(With the external shunt resistance and CR connection)

- a1. Normal operation : IGBT ON and carrying current.
- a2. Short circuit current detection (SC trigger).
- a3. Hard IGBT gate interrupt.
- a4. IGBT turns OFF.
- a5. FO timer operation starts : The pulse width of the Fo signal is set by the external capacitor C_{FO}.
- a6. Input "L" : IGBT OFF state.
- a7. Input "H" : IGBT ON state, but during the Fo active signal period the IGBT doesn't turn ON.
- a8. IGBT OFF state.



[B] Under-Voltage Protection (Lower-arm, UVd)

- b1. Control supply voltage rises : After the voltage level reaches UV_{Dr}, the circuits start to operate when next input is applied.
- b2. Normal operation : IGBT ON and carrying current.
- b3. Under voltage trip (UV_{Dt}).
- b4. IGBT OFF in spite of control input condition.
- b5. FO operation starts.
- b6. Under voltage reset (UV_{Dr}).
- b7. Normal operation : IGBT ON and carrying current.

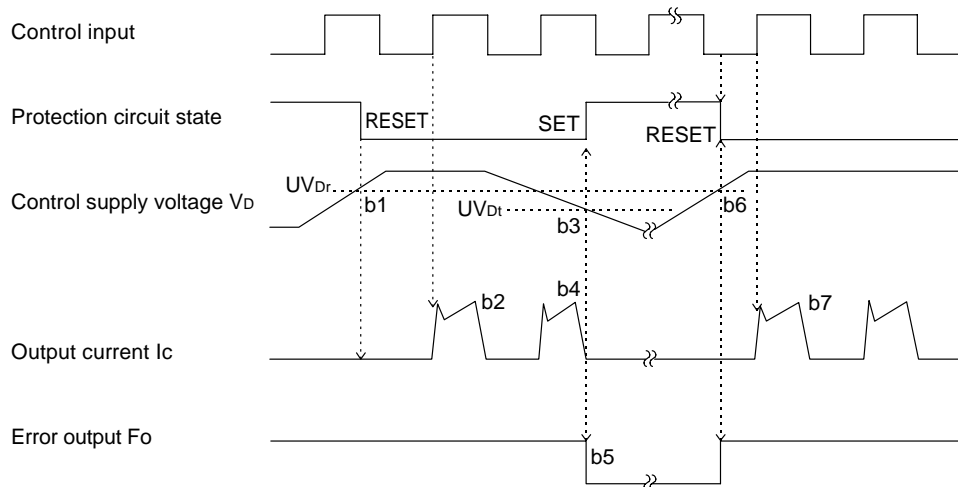

[C] Under-Voltage Protection (Upper-arm, UVDB)

- c1. Control supply voltage rises : After the voltage reaches UVDBr, the circuits start to operate when next input is applied.
- c2. Normal operation : IGBT ON and carrying current.
- c3. Under voltage trip (UVDBt).
- c4. IGBT OFF in spite of control input condition, but there is no Fo signal output.
- c5. Under voltage reset (UVDBr).
- c6. Normal operation : IGBT ON and carrying current.

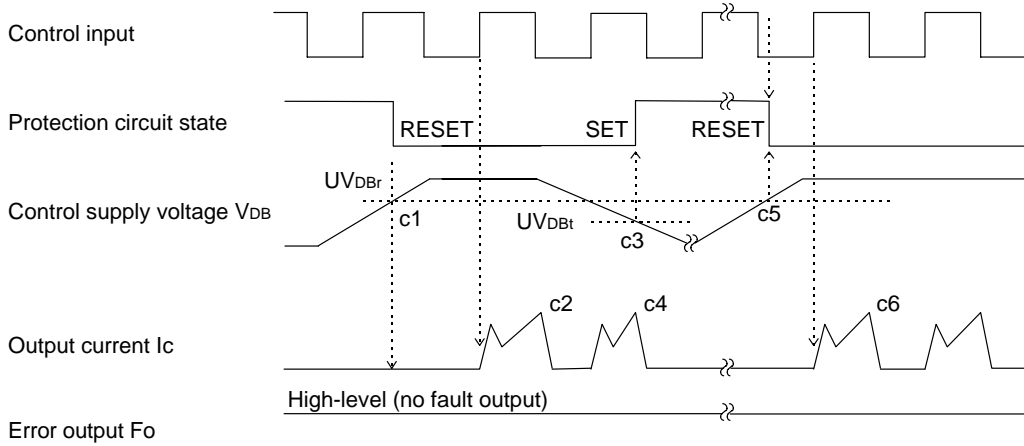
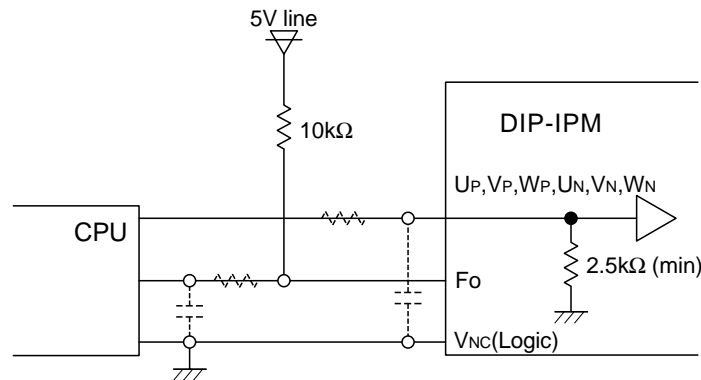

Fig. 6 RECOMMENDED CPU I/O INTERFACE CIRCUIT



Note : RC coupling at each input (parts shown dotted) may change depending on the PWM control scheme used in the application and the wiring impedance of the application's printed circuit board.
The DIP-IPM input signal section integrates a 2.5kΩ(min) pull-down resistor. Therefore, when using a external filtering resistor, care must be taken to satisfy the turn-on threshold voltage requirement.

Fig. 7 RECOMMENDED WIRING OF SHUNT RESISTANCE

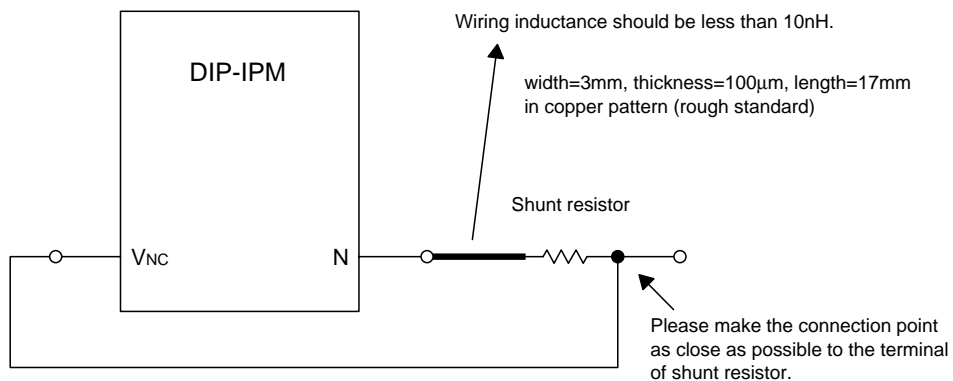
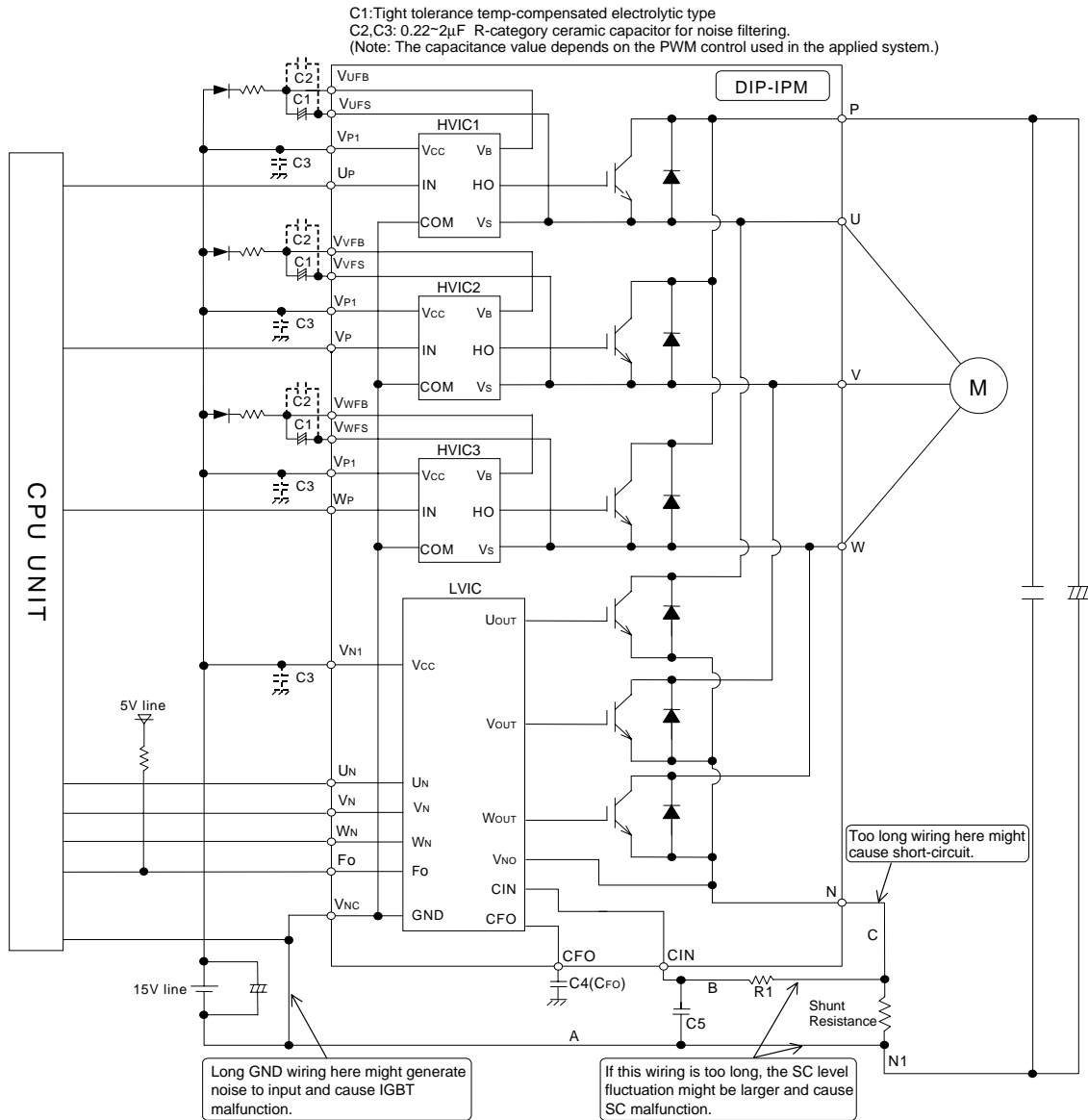

Fig. 8 TYPICAL DIP-IPM APPLICATION CIRCUIT EXAMPLE



- Note 1:** To prevent the input signals oscillation, the wiring of each input should be as short as possible. (Less than 2cm)
- 2:** By virtue of integrating an application specific type HVIC inside the module, direct coupling to CPU terminals without any opto-coupler or transformer isolation is possible.
- 3:** Fo output is open collector type. This signal line should be pulled up to the positive side of the 5V power supply with approximately 10kΩ resistor.
- 4:** Fo output pulse width is determined by the external capacitor between CFO and VNC terminals (CFO). (Example : CFO = 22 nF → tFO = 1.8 ms (typ.))
- 5:** The logic of input signal is high-active. The DIP-IPM input signal section integrates a 2.5kΩ (min) pull-down resistor. Therefore, when using external filtering resistor, care must be taken to satisfy the turn-on threshold voltage requirement.
- 6:** To prevent malfunction of protection, the wiring of A, B, C should be as short as possible.
- 7:** Please set the R1C5 time constant in the range 1.5~2μs.
- 8:** Each capacitor should be located as nearby the pins of the DIP-IPM as possible.
- 9:** To prevent surge destruction, the wiring between the smoothing capacitor and the P&N1 pins should be as short as possible. Approximately a 0.1~0.22μF snubber capacitor between the P&N1 pins is recommended.